

SIDE-POWER

Thruster systems

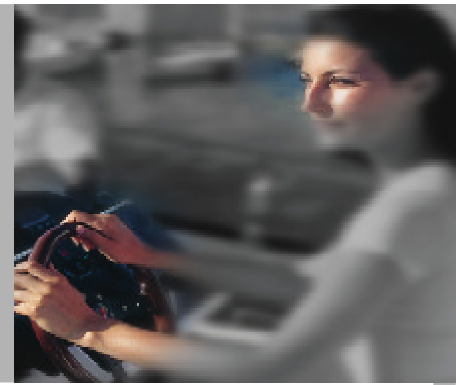

SP 95 T



MAIN FEATURES

Thrust at 10,5 / 21 V	95 kg / 209 lbs.
Power	6 kW / 8 Hp
Tunnel diameter	185 mm / 7,3"
Propulsion system	Twin
Voltage	12 V or 24 V
Weight	31 kg / 68 lbs.
Boat size	38 - 55 foot
Current draw	nom. 680 A (12 V) / 340 (24 V)
Min. battery CCA DIN	700 (12 V) / 350 (24 V)

This model is recognised as the most powerful thruster in this tunnel diameter. It is an upgrade from the test winning 7Hp Twin and has continued it's remarkable success.

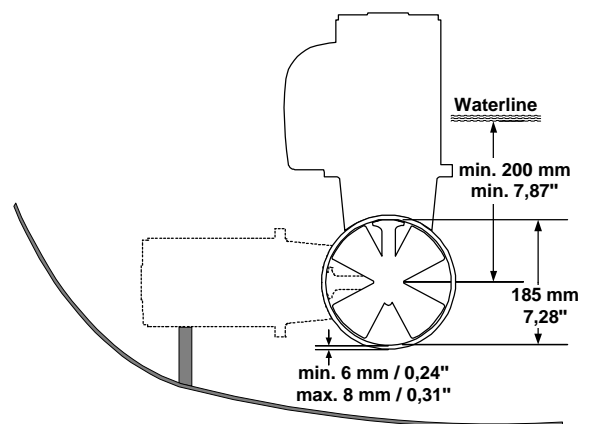
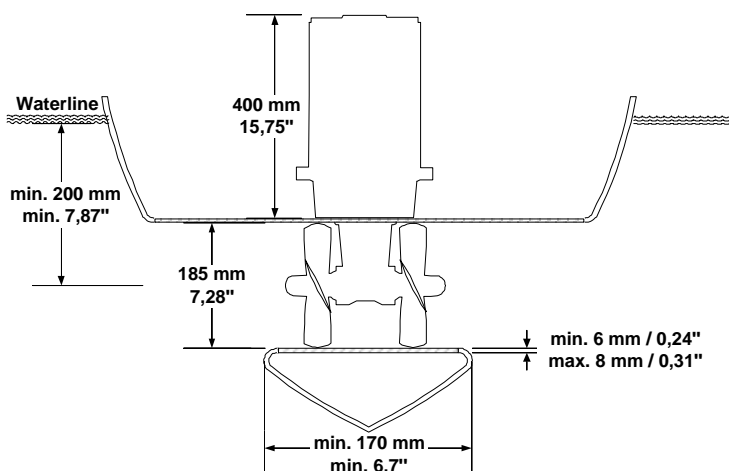

Sleipner Motor AS

P.O. Box 519
N-1612 Fredrikstad
Norway

Tel: +47 69 30 00 60
Fax: +47 69 30 00 70

www.side-power.com
sidepower@sleipner.no

